

Software objects a real blast

Corus Scunthorpe, the largest UK integrated Steel Works recently undertook a major renewal of plant in its Turbo Boiler House. The opportunity was taken to completely re-engineer its control and information system. The requirements for high availability and uptime for the critical air blast to the furnaces resulted in Wonderware Application Server and other ArchestrA products being used. The system is a significant advance upon the legacy solution, offering enhanced redundancy, better up time and easier operation.

*“... deployment was a key aspect as the next blower could be done without stopping the first – with full confidence that Wonderware Application Server would perform correctly”,
Martyn King,
Project Engineer, Corus Automation Solutions.*

The Turbo Boiler House is a critical part of the process at Scunthorpe. Although it generates electricity from the multiple boilers it is the supply of continuous air for the blast furnaces that is the key function. The air blast is created by five steam turbines that drive compressors, these are in some cases duplex and are connected via a switched manifold system to allow cross- and top-up feeding and thus ensure that the blast is maintained. From the boiler house the air is fed to stoves which increase the temperature of the air so that it can smelt the iron ore in the blast furnaces; failure of the air supply could result in significant loss of production and knock on effects to all areas of Steel production.

the opportunities in deploying information systems to enhance production and reduce business risk. The Turbo Boiler House had several legacy DCS technology systems to run the equipment but this was seen to be a risk owing to increasing difficulty in spare part procurement, know-how and reliability. The decision to replace the system was taken in tandem with the decision to refurbish the capital equipment (in particular the turbines); the phased roll-out of the refurbishment being ideal for changing the control and information scheme.

For the replacement system selection was made for the technology vendor and also for the integration partner. The key issue surrounding the technology was redundancy and the method of its deployment. During this evaluation Wonderware Application Server was seen to have an effective redundancy solution and also allowed a structured approach to be taken using re-usable objects – this was ideal for the boiler house as much of the generating equipment (air and electricity) was the same (or very similar).

The Integration was undertaken by Corus Northern Engineering Services, Automation Solutions. The competitively bid tender being placed with them owing to their experience in the application and the business and operational benefits demonstrated in their proposal.

Method...

CNES started by taking a top-down approach. This involved modelling the plant in the Wonderware Application Server Galaxy from ‘Corus Scunthorpe’ downwards all the way to

Legacy...

The situation at the site is one of continual renewal, with vast inter-connected steel making processes requiring careful consideration of consequential effects of engineering, and of

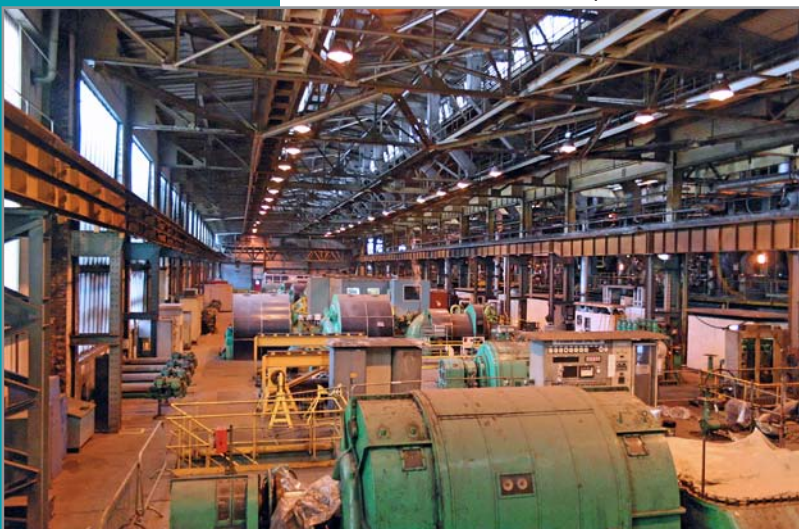

CORUS' turbo blower house at Scunthorpe



Air intake and Blast manifold

the plant sub-component level. Although this was focussed around the boiler house this does open the opportunity for on-going integration (such as to the coke ovens and by-products plant). Work was then commenced on defining each module from the bottom up.

The learning curve for Wonderware Application Server use and deployment was speeded by on-site training from SolutionsPT and by consultancy assistance during the first stage. This was undertaken by Chris Jackson, Wonderware Application Server specialist with SolutionsPT.

Having established the method in a highly structured way, Corus Automation Solutions was able to give undivided attention to the functionality and quality of each object that

they developed, knowing that Wonderware Application Server would take care of the integration and facilitate easier re-deployment of that work during later stages of the programme. This has already delivered benefits in the roll-out, “deployment was a key aspect as the next blower could be done without stopping the first – with full confidence that Wonderware Application Server would perform correctly”, said Martyn King, Project Engineer, Corus Automation Solutions.

Payback...

The project was of significant value and payback is expected within 18 to 24 months, according to the Corus team’s justification. This is mainly driven by the first order savings of legacy system costs and also by harder to measure but very important enhanced up-time and better control.

The requirement for system redundancy was the item that had highest functional priority. Whilst this in many ways is reflected in the system hardware the software was to be capable of undertaking master / slave duty. This is readily achieved in Wonderware Application Server as it is a standard integrated object. This feature was a strong reason that Wonderware Application Server was selected in favour of its nearest competitor.

During the factory acceptance test all modules were deployed and key sections (such as condition monitoring) were simulated using specialist signal generators. Martyn explained that the objects (from Wonderware Application Server) were then “un-deployed”. The reason for this being that during later site commissioning and testing the objects could be deployed as they were needed, and tested in situ at that time – ensuring that everything had been tested; working on the basis of “not deployed = not tested”. This use of Wonderware Application Server functionality is effective and simple in delivering quality application.

Structure...

The system is divided into three main functional areas; the servers, the plant floor control and that supervisory control room. The Wonderware Application Server runs on two servers in Master / Slave whilst the Historian that collects and archives all the plant data in real time runs on single server with a RAID hard disk array. The network is fibre optic and is in dual redundant ring mode, allowing for fibre damage as well as any node faults. The plant floor has workstations running InTouch HMI and dual redundant Ethernet IP connection to logic controllers. The turbines have Bentley Nevada condition monitoring which is connected through the controllers to the system for display, reporting

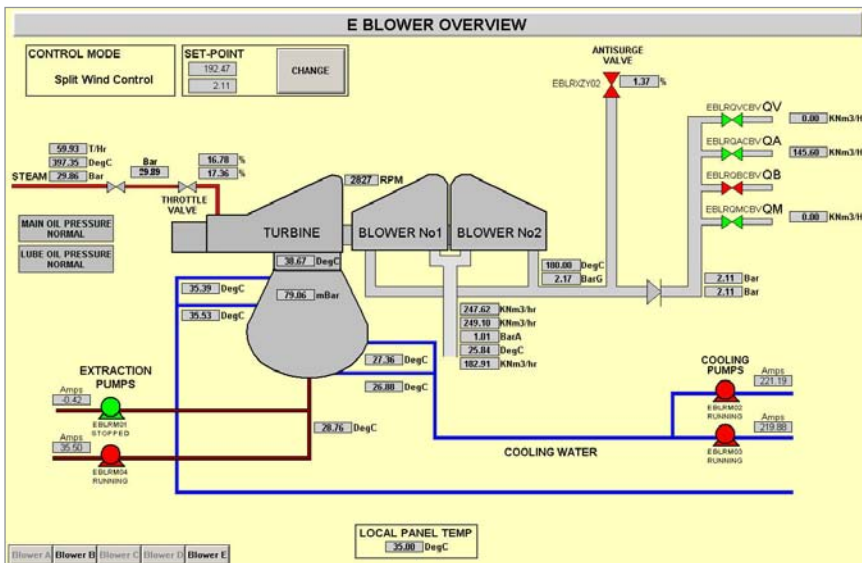

E Blower - overview

and historisation. This allows any instances of abnormal operation to be captured for detailed analysis. Much of the system hardware and configuration was delivered by SolutionsPT's specialist division, HardwarePT.

The control room is currently located in the centre of the boiler house, eventually this will be repositioned. This move requires more remote control, something that is built in to the new system in anticipation of this. In

understands the benefits of the Wonderware Application Server-based system (they agreed to this solution as part of CNES's proposal). The single Wonderware Application Server galaxy allows everything on the site to be interconnected. Following Wonderware Application Server implementation Corus does not want multiple systems; everything has to go in the one – Wonderware Application Server. The next likely phase after completion of this roll-out is the control of the 5 Boilers themselves.”

The Turbo Blower project at Scunthorpe is a definitive application of Wonderware Application Server, making full use of the product's capabilities, and thereby delivering real and measurable business and operational benefits. A true wind of change!

§



Control room displays

the Control Room a large bank of flat screen displays shows comprehensive information, set points, sensor values and alarms for boiler house operators. This functionality will be extended in the future with additional reporting.

A single solution...

Looking to the future Martyn added, “Our customer (Corus at Scunthorpe) completely

Wonderware UK wishes to thank the following company for their valued contribution to this success story...

CORUS Northern Engineering Services Automation Solutions

T: +44 (0) 1724 405377

M: +44 (0) 7793 170405

www.corusservices.com



© 2009 by SolutionsPT Ltd. All rights reserved. No part of this document may be reproduced, stored in or introduced into a retrieval system, or transmitted in any form or by any means (electronic, mechanical, photocopying, recording or otherwise), or for any purpose, without the express written permission of SolutionsPT Ltd.

Invensys, Wonderware, Archestra, InTouch and SCADAAlarm are trademarks of Invensys plc, its subsidiaries and affiliated companies. All other brands and product names may be the trademarks or service marks of their respective owners. Wonderware United Kingdom & Wonderware Ireland are trading names of SolutionsPT, an independent Wonderware software distribution partner. All rights reserved.

Contact SolutionsPT for information about software products for industrial automation.

SolutionsPT

Wonderware United Kingdom and Wonderware Ireland, Unit 1 Oakfield Road, Cheadle Royal Business Park, Cheadle SK8 3GX
+44 (0)161 495 4698

info@wonderware.co.uk

www.wonderware.co.uk